

# SCA121T Series

## Stand Alone Inclinometer

### Dual Axis Analog Output

#### FEATURES

- Silicon 3D MEMS sensor
- 0,1° accuracy
- Resolution < 0,001°
- Operating temperature range -40...+85 °C
- Long term stability < 0,02°
- Shock resistance >20 000 g
- Sensing element -3 dB @ 18 Hz
- Main dimensions: 30x30x13 mm size, single or dual axis
- Voltage output
- RoHS compatible

#### BENEFITS

- Excellent long term stability
- Sensing element controlled frequency response
- Outstanding shock durability
- Harsh environment robustness

#### APPLICATIONS

- Platform tilt measurement
- Equipment and instrument condition monitoring
- Inclination based position measurement
- Rotational orientation measurement

For customised product please contact VTI Technologies

### ELECTRICAL CHARACTERISTICS

Parameter	Condition	Min.	Typ	Max.	Units	
Supply voltage	Unregulated or regulated ratiometric	7	16	35	V	Applies to: -D03, -D07 Applies to: -D05
		4.75	5	5.25	V	
Current consumption			5		mA	
Output load	Resistive	10			kΩ	
	Capacitive			20	nF	

### PERFORMANCE CHARACTERISTICS

Parameter	Condition	SCA121T-D03	SCA121T-D07	SCA121T-D05	Units
Measuring range <sup>(1)</sup>		±90	±30	±90	°
Supply voltage		7...35	7...35	5 ±0.25	V
Measuring axis	(see "Directions")	X-Y	X-Y	X-Y	
Offset <sup>(2,5)</sup>	Output at 0°	2.5	2.5	2.5	V
Offset zero point error <sup>(5)</sup>	Max. deviation	1	1	1	°
Offset temperature error	0...70 °C	±0.2	±0.2	±0.2	°
	-25...85 °C	±0.6	±0.6	±0.6	°
Sensitivity		2	4	2	V/g
		35	70	35	mV/g(@offset pos.)
Sensitivity temperature error <sup>(5)</sup>	0...70 °C	-0.8...0.3	-0.8...0.3	-0.8...0.3	%
	-25...85 °C	-1.5...0.5	-1.5...0.5	-1.5...0.5	%
Nonlinearity	Sinus output	N/A	0.1	N/A	°
Frequency response -3 dB <sup>(3)</sup>		18	18	18	Hz
Cross-axis sensitivity <sup>(4)</sup>		3	3	3	%

Typical values unless otherwise specified.

Note 1 The measuring range is limited by the sensitivity and offset.

Note 2 Offset specified as Output @ 0°.

Note 3 The frequency response is determined by the sensing element's internal gas damping. The output has true DC (0 Hz) response.

Note 4 The cross-axis sensitivity determines how much inclination, perpendicular to the measuring axis, couples to the output.

Note 5 For optimum zero point accuracy, mounting angle of the part can be adjusted.

### MEASURING DIRECTIONS

#### X-axis

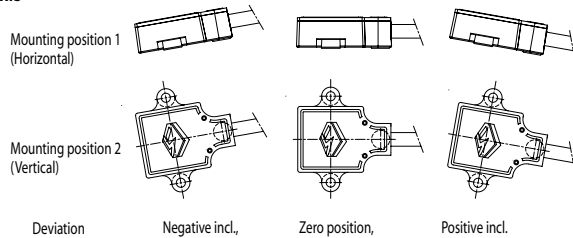

#### Y-axis

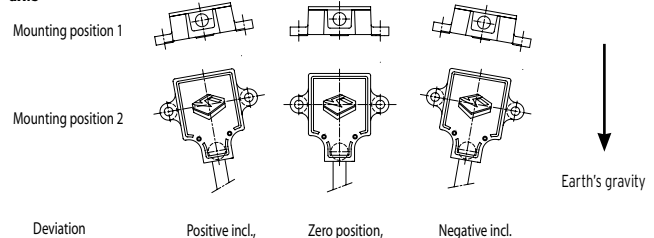

Figure 1. Positions

#### Notes:

- It is important that the part is parallel to the mounting plane, and that the output equals the zero value when sensor is in zero position.
- Zero position: Please note the picture above which provides information on how the output of the accelerometer behaves in different circumstances when assembled. Please also note that you can rotate the part around the measuring plane for optimum mounting location.

## ELECTRICAL CONNECTION

### SCA121T series

Wire color	Name	Function
Blue	GND	Ground
Red	V <sub>cc</sub>	Power supply
Yellow	Out X	X-axis output
Green	Out Y	Y-axis output
White		Not connected

## MECHANICAL SPECIFICATION

Cable length: -D03, -D07 30 cm  
 -D05 110 cm  
 Total weight: Approx. 60 grams  
 Protection class: IP66  
 Housing: Zinc casting with passivation

## MOUNTING

The sensor module is to be mounted on a flat and smooth surface with 2 screws, dimension M4. Mounting torque 5 ±1 Nm.

## SENSOR DIMENSIONS

Dimensions in mm.

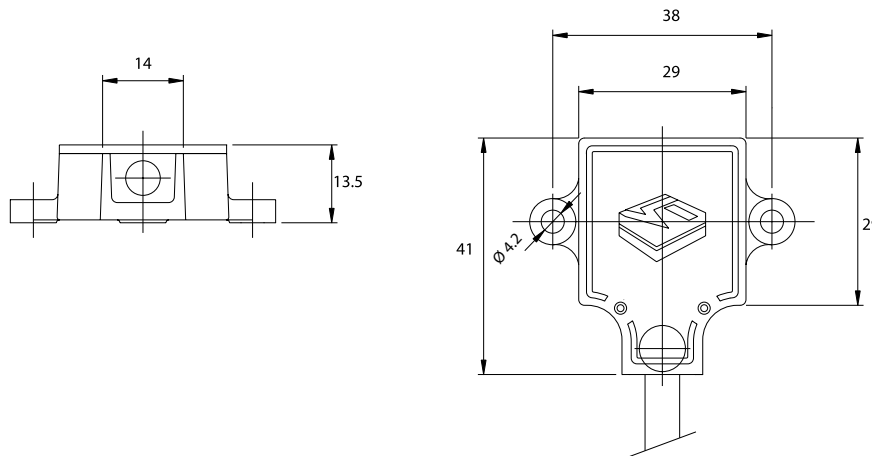

Figure 2.

## VOLTAGE TO ANGLE CONVERSION

$$\text{Inclination angle} = \arcsin \left( \frac{V_{\text{out}} - \text{Offset}}{\text{Sensitivity}} \right)$$

where:

V<sub>out</sub> = analog output [V]

Offset = 2.5 V, output at 0° inclination position

Sensitivity = sensitivity of device [V/q]