

Data Sheet

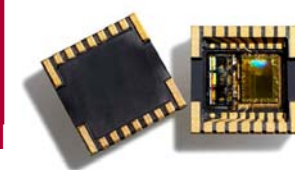

SCA3000-E02 3-AXIS ULTRA LOW POWER ACCELEROMETER WITH DIGITAL I²C INTERFACE

Features

- 2.35 V – 3.6 V supply voltage, 1.7 V - 3.6 V digital I/O voltage
- ±3 g measurement range
- I²C digital interface: V2.1 compliant, 10-bit addressing, supports standard mode
- Selectable frequency response
- Ultra low current consumption (2.5 V, 200 μA typ)
- 64 samples/axis buffer memory for output acceleration data and advanced features enable significant power and resource savings at system level
- Interrupt signal triggered by motion and free fall
- Size 7x7x1.8 mm
- Proven capacitive 3D-MEMS technology
- High shock durability
- RoHS compliant / lead free soldering

Applications

SCA3000-E02 is targeted to battery operated wrist and hand-held devices. Typical applications are but not limited

- Motion activated functions in mobile terminals and antitheft systems
- Gaming input devices
- Inclination sensing in digital inclinometers
- Tilt compensation in electronic compass
- Hard disk protection
- Pedometers and activity monitors

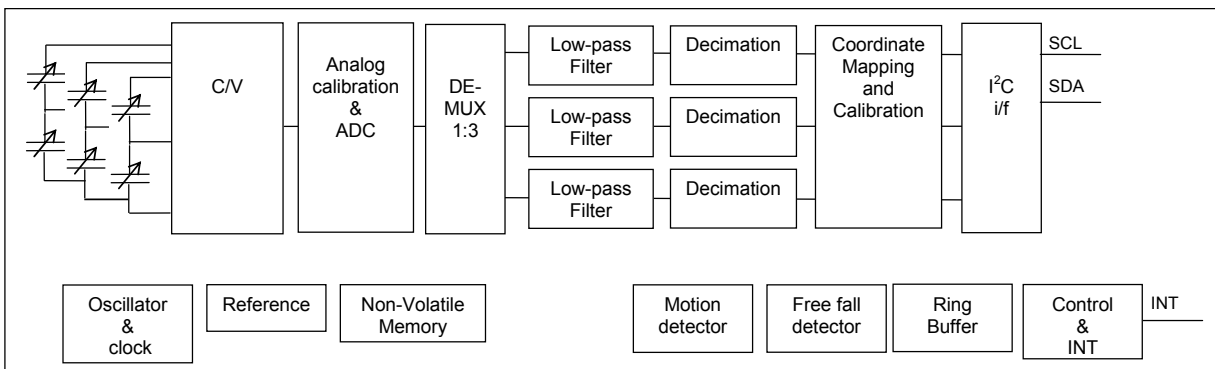

Figure 1 SCA3000-E02 Block Diagram

Performance Characteristics ¹⁾

Parameter	Condition	Typical supply range 2.35 – 2.7 V			Extended supply range 2.7 – 3.6 V			Units
		Min	Typ ²⁾	Max	Min	Typ ²⁾	Max	
Analog and digital Vdd		2.35	2.5	2.7	-	3.3	-	V
Digital I/O Vdd	Vdd ≥ Digital I/O Vdd	1.7	1.8 / 2.5	2.7	-	3.3	-	V
Operating temperature **		-40	-	85	-40	-	85	°C
Current consumption *	Reset ³⁾	-	<7	12	-	<9	-	μA
	Active	-	200	240	-	250	-	μA
	Motion Detection mode	-	170	210	-	210	-	μA
Acceleration range * ⁴⁾	Nominal	-3	-	3	-	± 3	-	g
Offset calibration error * ⁵⁾	Z-axis +1g position	-40	-	40	-	± 100	-	mg
Offset temperature error ** ⁶⁾	-40 ... +85 °C	-3	±0.8	3	-	±0.8	-	mg/°C
Sensitivity * ⁷⁾		-	1000	-	1000	-	-	Count/g
Sensitivity calibration error *		-1.5	-	+1.5	-	± 1	-	%
Sensitivity temperature error ** ⁸⁾	-40 ... +85 °C	-	±0.01	-	-	±0.01	-	%/°C
Non-Linearity ** ⁹⁾		-3	±1	3	-	1	-	% FS
Cross-Axis sensitivity ** ¹⁰⁾		-	3	-	-	3	-	%
Bandwidth ** ¹¹⁾	Measurement mode	32	40	48	-	40	-	Hz
	Narrow band measurement mode	9	11	13	-	11	-	Hz
Noise ** ¹²⁾	Measurement mode	-	9	18	-	9	-	mg RMS
	Narrow band measurement mode	-	5	10	-	5	-	mg RMS
Output data rate **	Measurement mode	100	125	150	-	130	-	Hz
	Narrow band measurement mode	50	63	75	-	63	-	Hz
Turn on time ** ¹³⁾	Measurement mode	-	30	70	-	30	-	ms
	Narrow band measurement mode	-	200	400	-	200	-	ms
I ² C clock rate **		-	-	100	-	-	100	kHz

* 100% tested in production

** Qualified during product validation

1) The product is factory calibrated at 2.5 V in room temperature.

2) Typical values are not guaranteed.

3) Includes the current through the internal 400 kΩ pull-up resistor connected to digital I/O Vdd.

4) Range defined as $\sqrt{x^2+y^2+z^2} \leq 3g$. The measuring range is tested on sensing element level. FS = 3g.

5) Soldering process can cause offset shift which is typically less than 75 mg. Please see TN54_SCA3000_Assembly_Instructions for further details.

6) Offset temperature error = {Count(0g)-Offset} / Sensitivity [g]. Sensitivity = Calibrated sensitivity. Offset= Calibrated offset.

7) Sensitivity = {Count(+1g) - Count(-1g)}/2 [Count/g].

8) Sensitivity temperature error = {[Count(+1g)-Count(-1g)]/2 - Sensitivity} / Sensitivity x 100% [%]. Sensitivity = Calibrated sensitivity.

9) From straight line through sensitivity calibration (+1g, -1g) points.

10) The cross-axis sensitivity determines how much acceleration, perpendicular to the measuring axis, couples to the output. The total cross-axis sensitivity is the geometric sum of the sensitivities of the two axes which are perpendicular to the measuring axis. The angular alignment error between X, Y and Z axis is included into the cross axis sensitivity.

11) Frequency responses according to Figure 3 and Figure 4.

12) Average noise/axis over the measurement bandwidth defined as $\sqrt{\frac{1}{3}(n_x^2+n_y^2+n_z^2)}$, where n_x , n_y and n_z are

the measured signal's standard deviation due to noise in x, y and z directions.

13) Settling error less than 1% of FS.

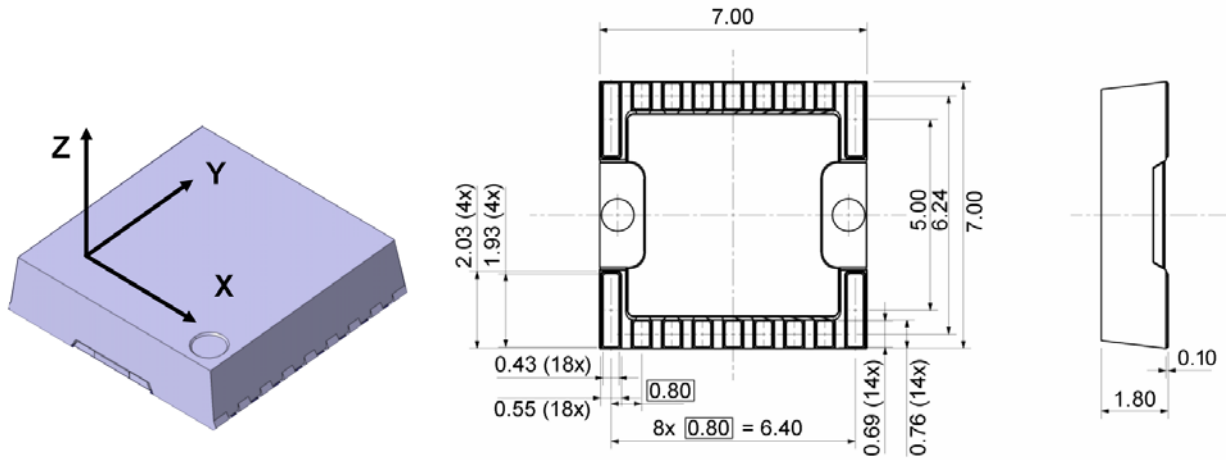

Figure 2 Sensing directions and package dimensions in mm with $\pm 50 \mu\text{m}$ tolerance.

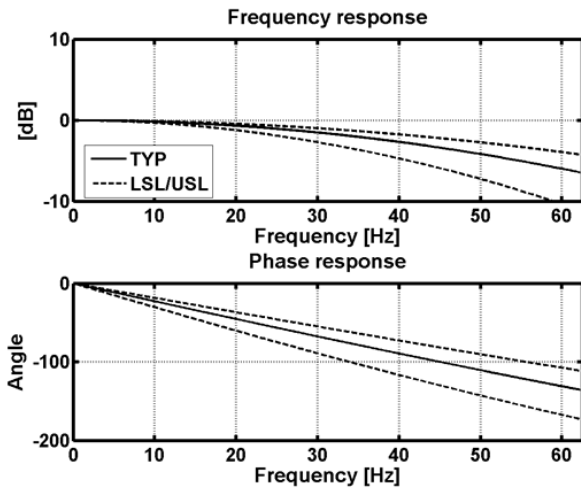

Figure 3 Frequency response of SCA3000-E02 in measurement mode

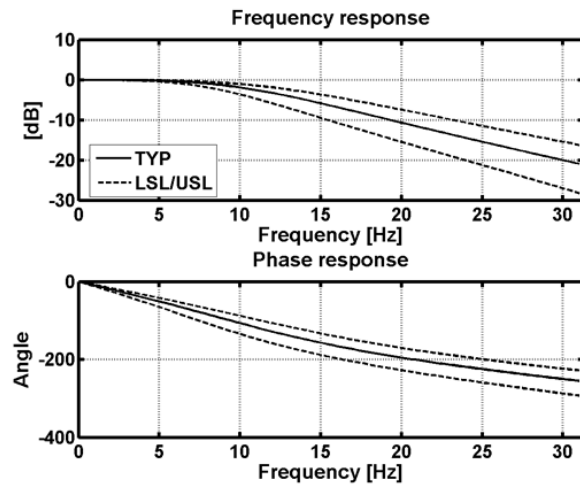

Figure 4 Frequency response of SCA3000-E02 in bypass measurement mode

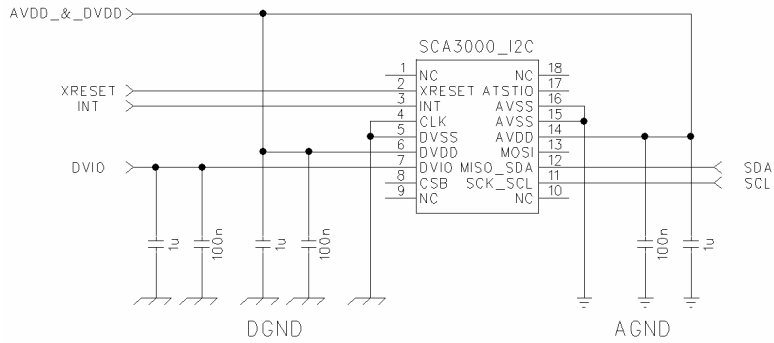

Figure 5 Application schematic

Pin #	Name	Function
1	NC	Not connected
2	XRESET	External reset, active low
3	INT	Interrupt output
4	CLK	Digital ground
5	DVSS	Digital ground
6	DVDD	Digital supply
7	DVIO	Digital I/O supply
8	CSB	Not connected
9	NC	Not connected
10	NC	Not connected
11	SCK_SCL	I ² C clock (SCL)
12	MISO_SDA	I ² C data (SDA)
13	MOSI	Not connected
14	AVDD	Analog supply
15	AVSS	Analog ground
16	AVSS	Analog ground
17	ATSTIO	Not connected
18	NC	Not connected

Table 1 Pin descriptions

Document Change Control

Rev.	Date	Change Description
A	21-Apr-06	1 st official release
A.01	13-Jun-06	Dimensions updated
A.02	31-Oct-07	Figure 2 updated
B	28-Aug-08	Performance characteristics updated
B.01	08-Sep-09	Note 5 on performance characteristics added