



**SCC1300-D0X PWB**  
Specification

## 1 SCC1300-D0X PWB

The purpose of SCC1300-D0X PWB is to enable fast prototyping.

SCC1300-D0X PWB includes

- SCC1300-D01 sensor soldered on PWB
- PWB design #VTI29886 with pin headers
- Step up converter circuitry to create 5 V supply from external 3.3 V supply
  - SCC1300-D0X PWB can be powered with only 3.3 V
- Connectors and passive components

Refer to corresponding SCC1300-D0X datasheet when using the SCC1300-D0X PWB.

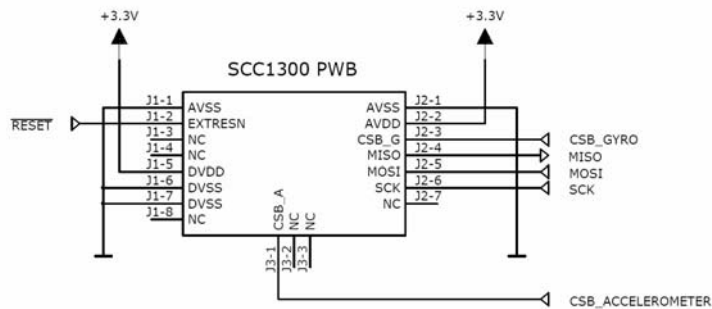

Figure 1. SCC1300-D0X PWB pin out and external connections.

Table 1. BOM of SCC1300-D0X PWB.

Item	Qty	Ref	Part Name / type	Value
1	6	C1-5 C11	Capacitor 0603	100 nF
2	1	C10	Capacitor 0603	3.3 pF
3	1	C6	Capacitor 0805	1 μF
4	1	C7	Capacitor 0805/10P_AVH_50V	470 nF
5	1	C13	Capacitor 1206	10uF
6	3	C8-9 C12	Capacitor 1210/X5R	4.7μF
7	1	R3	Ferrite bead 0603/BLM18HGXXX 1GHz	1kΩ
8	1	L2	Inductor 7X7/10U/EPCOS	10μH
9	1	J3	3-pin through hole pin header, pitch 100 mils, pin size 0.63x0.63mm, length ~5.85mm (example mating part: Samtec: SSQ-108-01-S-S)	
10	1	J2	7-pin through hole pin header, pitch 100 mils, pin size 0.63x0.63mm, length ~5.85mm (example mating part: Samtec: SSQ-108-01-S-S)	
11	1	J1	8-pin through hole pin header, pitch 100 mils, pin size 0.63x0.63mm, length ~5.85mm (example mating part: Samtec: SSQ-107-01-S-S)	
12	1	V1	Diode MBRS2040LT3/SMB	
13	1	L1	Inductor 1210/10P_EPCOSuH	47μH
14	1	R2	Resistor 0603	130kΩ
15	1	R1	Resistor 0603	390kΩ
16	1	R4	Resistor 0805	10Ω
17	1	A1	Switching Regulator LT3467/SOT23-6	
18	1	U1	SCC1300 Gyro Accelerometer Combo	

Detailed pictures of SCC1300-D0X PWB are presented in following pages:

- PWB layout
- Assembly drawings
- Circuit diagram

PCB Mechanical dimensions:

- Length 42.9 mm
- Width 27.4 mm
- Height 15.1 mm (incl. components and pin header)

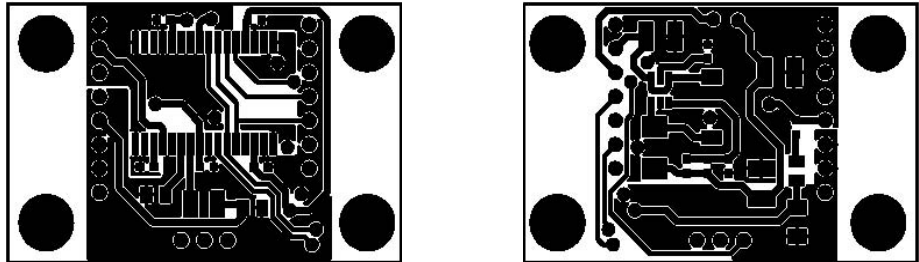

Figure 2. Layouts of SCC1300-D0X PWB (picture aspect ratio is not 1:1).

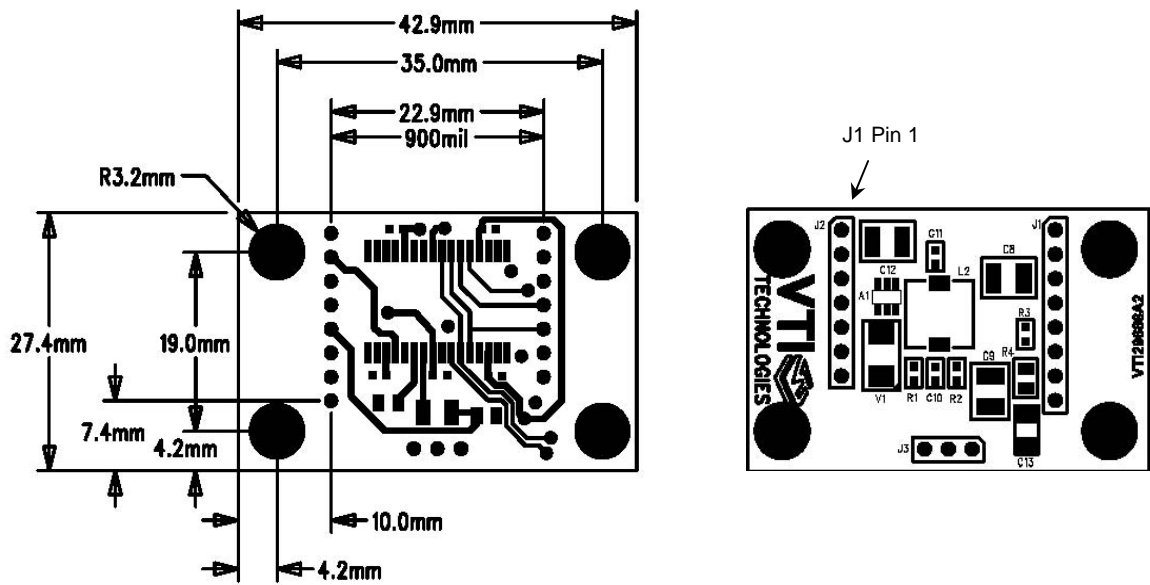

Figure 3. TOP (left) and BOTTOM (right) view assembly drawings for SCC1300-D0X PWB (picture aspect ratio not 1:1).

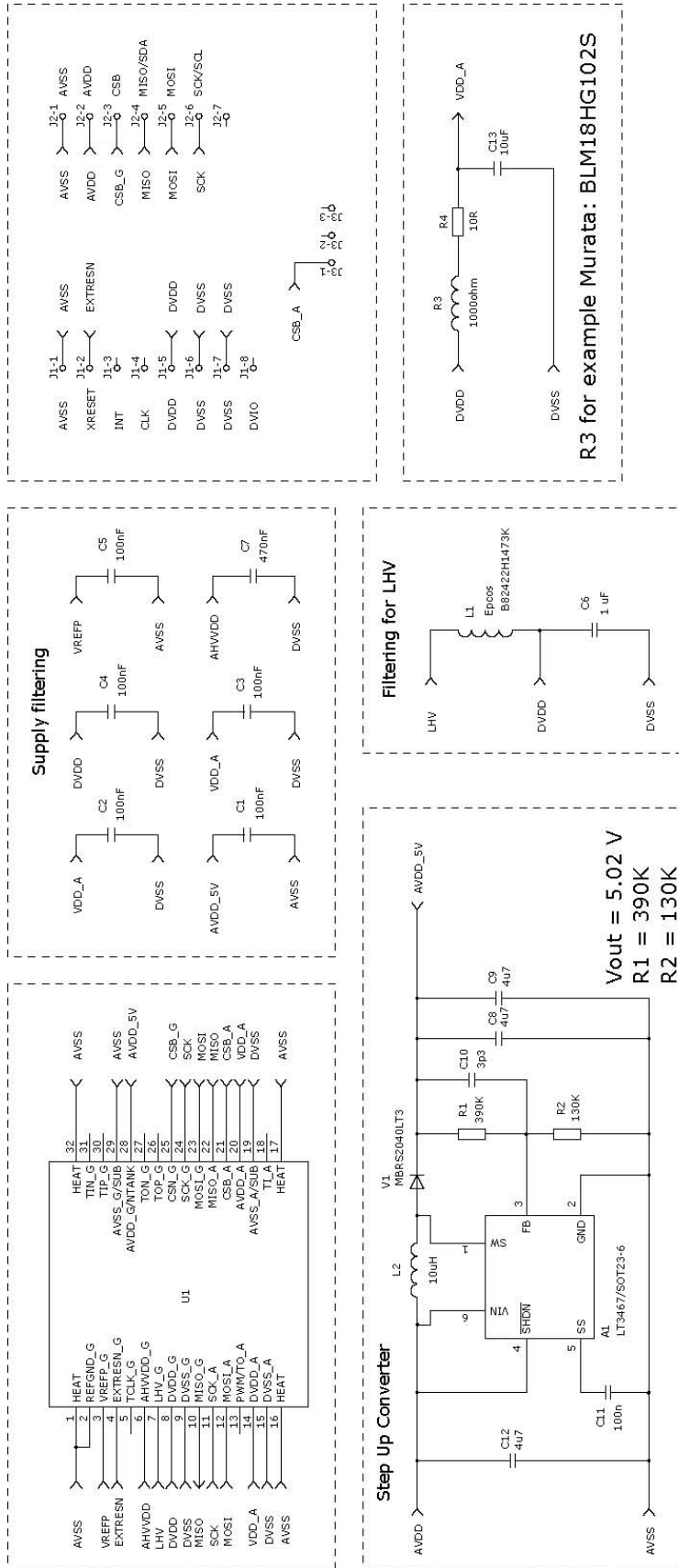

Figure 4. SCC1300-D0X PWB circuit diagram.

## 2 Document Revision History

Version	Date	Change Description	
1.0	11.11.2009	First version	JUP